

M/A-COM Drivers for GaAs FET Switches And Digital Attenuators

Introduction

Many of M/A-COM's GaAs FET switches and digital attenuators cannot operate directly with simple TTL or CMOS logic, but instead require external circuits to provide appropriate control voltages. This application note, an update of M539, *Drivers for GaAs FET MMIC Switches and Digital Attenuators*, provides information on M/A-COM's SW-109 and SWD-119 drivers and other commercially available digital logic IC's for control of switches and digital attenuators.

GaAs FET's

GaAs MMIC control devices such as switches and digital attenuators typically employ Field Effect Transistors (FET's). The most common FET is the n-channel depletion mode device, which has low source-to-drain resistance in the absence of a gate bias, and allows a current I_{DSS} to flow. With the application of a negative gate bias voltage, the electric field below the gate causes the conduction channel to narrow, increasing the source-to-drain resistance. The gate voltage that creates a high enough resistance to reduce the source-to-drain current to (typically) 1 - 2 percent of I_{DSS} is known as the pinch-off voltage. For M/A-COM FET's, the pinch-off voltage is typically -2.5 volts. If the transistor is biased at the extremes, (0 V and -5 V, typically), on and off switching results, providing the basis for both GaAs MMIC switches and digital attenuators.

Switch Circuit Topology

In switches, FET's are arranged in both series and shunt configurations. The series FET's provide a through-path for the on state, while the shunt FET's provide isolation for the off state. The operation of the switch requires that series FET's and shunt FET's associated with each switch state have opposite (or complementary) conduction states and therefore opposite (or complementary) gate biases. For example, **Figure 1** illustrates the operation of a typical dual control SPST GaAs MMIC switch. If the RF to RF1 path is on and the RF to RF2 path is off, then FET's Q2 and Q4 are biased on, while Q1 and Q3 are biased off.

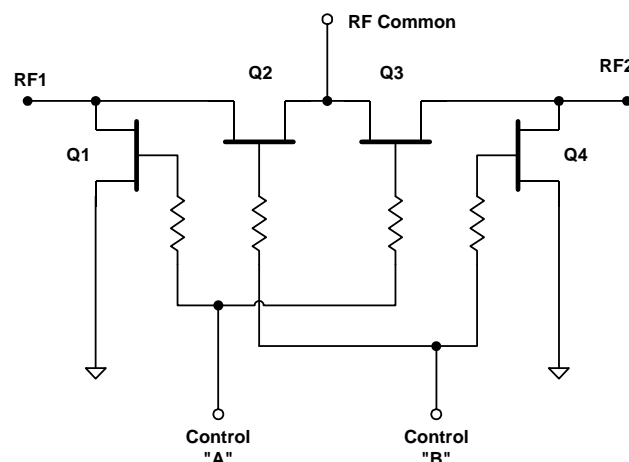

Dual Control Switch Truth Table

Control A	Control B	RF Common to RF1	RF Common to RF2
-5 V	0 V	On	Off
0 V	-5 V	Off	On

Typical complementary logic control voltages:

Logic low	0 V to -2 V @ 20 μ A max.
Logic high	-5 V to 40 μ A typ. To -8 V @ 200 μ A max.

Figure 1: Typical Dual Control Switch (SW-239, etc)

Digital attenuators use series/shunt stages with circuit components that form fixed attenuator pads, corresponding to digital attenuation bits, switched in or out of the transmission path, either individually or in combination. Switches require complementary bias voltages for each state, while digital attenuators require complementary bias voltage to activate each bit.

Figure 2 shows a 3-bit digital attenuator. Applying the correct bias voltage and its complement to any stage switches the pad for that stage into the RF signal path.

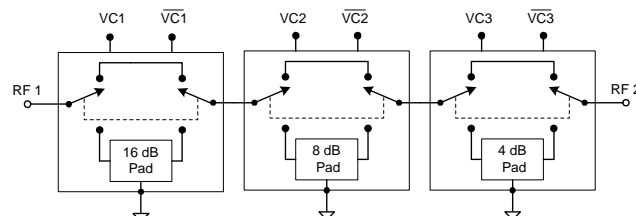

Figure 2: Digital Attenuator Based on Switched Pads (AT-230)

Specifications subject to change without notice.

- North America: Tel. (800) 366-2266, Fax (800) 618-8883
- Asia/Pacific: Tel. +81-44-844-8296, Fax +81-44-844-8298
- Europe: Tel. +44 (1344) 869 595, Fax +44 (1344) 300 020

Visit www.macom.com for additional data sheets and product information.

Built-in Drivers

Some of M/A-COM's newer switches and attenuators feature simplified control using CMOS (0 V, 2.7 V) or TTL (0 V, 5 V) logic, with no need for negative control voltages.

The Appendix to this application note lists some popular M/A-COM switches. The SW-277, SW-349, SW-394, and SW-399 include level shifting components for compatibility with positive CMOS or TTL control voltages, but these switches still require complementary control logic. The SW-335, SW65-0xxx series and related switches incorporate a CMOS driver circuit in the same package, along with the GaAs switching elements, for true single line control. Many future switches from M/A-COM will likely incorporate driver circuitry and switching elements together in small, low cost plastic packages.

The AT-226, AT-264, and AT-242 digital attenuators feature internal level shifting to provide control with a single CMOS input line for each attenuation bit. The AT65-0xxx series miniature digital attenuator modules incorporate CMOS driver circuitry to accomplish this

SWD-109 & SWD-119 Drivers

M/A-COM's SWD-109 and quad-channel SWD-119 provide the complementary control voltages necessary for driving GaAs FET switches and digital attenuators using a single control input per bit. Both the SWD-109 and SWD-119 incorporate buffering stages so that the drivers will switch with either standard TTL or CMOS logic level input. The devices employ standard CMOS analog fabrication techniques for low power consumption.

The devices consist of input buffers, inverters to generate complementary logic values, voltage translators, and output buffers, all designed to allow the designer the flexibility to optimize switch and attenuator performance.

To design a board with RF switches and attenuators, consider that modulation of the source-drain resistance in the FET's by input RF can lead to output compression and intermodulation distortion. Although GaAs FET switches and attenuators will operate well with nominal 0 V and -5 V for control, careful selection of the control voltages in the ranges of $-8\text{ V} \leq V_{\text{FEToff}} \leq -5\text{ V}$, and $0\text{ V} \leq V_{\text{FETon}} \leq 2\text{ V}$ can improve the maximum RF level (P1dB). With proper selection of positive and negative supply voltage, the SWD-109 and SWD-119 can both provide output control voltages in these ranges.

Another consideration in design with switches and attenuators is the elimination of crosstalk that can arise from RF leakage onto control lines. Most board designers take care of this by adding capacitance to ground on the control lines, shunting any RF energy to ground. The SW-109 and SWD-119 output buffers can drive load capacitance up to 25 pF.

Other Circuits as Drivers

You can use TTL and CMOS logic IC's to drive GaAs FET switches and attenuators. An ideal driver would run from a single supply voltage, consume little current, and introduce very little switching delay.

One driver technique that works well floats the channel of the FET's on the MMIC switch above ground potential through the addition of pull-up resistors and DC blocking and bypass capacitors. As shown in **Figure 3**, the circuit takes a voltage of 0 VDC, applied to either control port, and shifts it to -5 VDC at the attached FET gates to turn them off. A voltage of +5 VDC shifts to 0 VDC at the FET gates to turn them on.

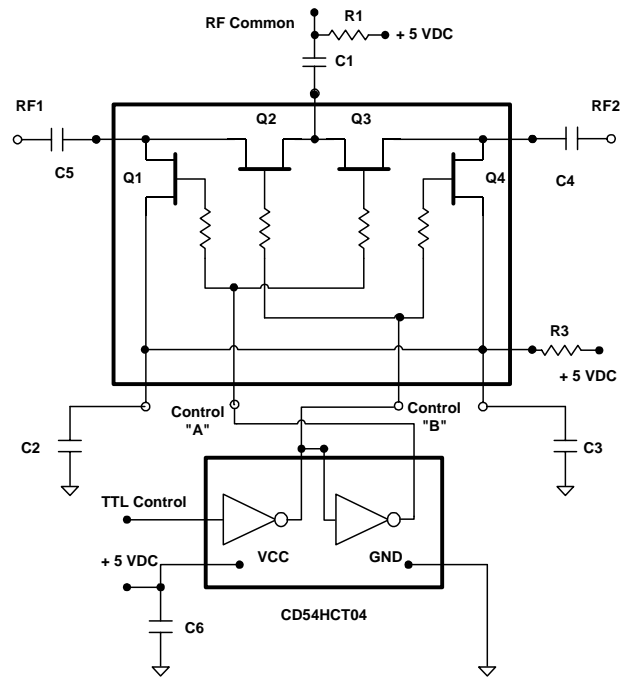

Control A	Control B	RF Common to RF 1	RF Common to RF 2
TTL Low	TTL High	ON	OFF
TTL High	TTL Low	OFF	ON

Figure 3: GaAs SPDT Switch with CMOS Driver

M/A-COM's dual control, negative bias switches and attenuators have intrinsic switching speeds as low as ~ 5 ns. A disadvantage of level shifting by floating the FET's is that the time constants of the bypass and blocking capacitors charging through the internal FET gate resistors will introduce some switching delays. As shown in the appendix, switches that incorporate level shifting on-chip typically have switching speeds ranging from several tens of nanoseconds to microseconds.

Specifications subject to change without notice.

- North America: Tel. (800) 366-2266, Fax (800) 618-8883
- Asia/Pacific: Tel.+81-44-844-8296, Fax +81-44-844-8298
- Europe: Tel. +44 (1344) 869 595, Fax+44 (1344) 300 020

Visit www.macom.com for additional data sheets and product information.

Figure 3 shows a dual control GaAs FET switch driven by the Texas Instruments CD54HCT04 high speed CMOS logic hex inverter, a CERDIP packaged device that can operate with CMOS logic input levels (0 V, 2.7 V) and drive TTL loads. Driving a dual control switch stage requires using two gates of the CD54HCT04, one to generate a buffered output, one to generate its complement. Each gate in the CD54HCT04 introduces a switching propagation delay of 20 ns. The DC current consumption of the entire hex device is less than 1 mA at + 5 VDC.

When designing with the CD54HCT04 as a driver, choose the DC blocking capacitors C1, C4, and C5, to give minimum insertion loss at the lowest desired operating frequency. Choose the bypass capacitors C2 and C3 to give maximum isolation at the highest desired operating frequency. Bypass capacitor C6, which has the same value as C2 and C3, shunts any RF signal leakage on the DC bias line at the hex inverter to ground. Use low series resistance, high Q capacitors, such as the American Technical Ceramic ATC100A series, for the lowest possible insertion loss.

The resistors R1 and R3 that connect the DC bias to the switch should have a value in the range of 10 to 50 kilohms to keep RF crosstalk as low as possible. Place the resistors, capacitors and ground vias as close to the body of the switch as possible to reduce inductance for the best RF performance.

Other popular logic IC's work well as drivers, depending upon your requirements for switching speed, DC power consumption, and RF linearity. Other hex inverters related to the CD54HCT04 that work well include the SOIC or plastic DIP packaged CD74HC04 and CD74HCT04, the slower CD54HC04, and the Fairchild DM74LS04.

With a 5 VDC supply voltage, the DM74LS04 provides output logic voltages of 0.25 V (logic low) and 3.4 V (logic high). To substitute the pin-compatible DM74SL04 for the CD54HCT04, you will have to add additional pull-up circuitry connected between the driver and the switch to raise the logic high to 5 VDC. This will result in slower switching speed and higher current consumption compared to the CD54HCT04.

The Texas Instruments SN54HC139 two to 4 line decoder also works well, as does the CD4041UB quad / true complement buffer. The CD4041UB provides four pairs of complementary outputs, and can provide a range of logic output voltages depending upon the supply voltage that you choose. With the CD4041UB supplying a bias of 8 VDC for the logic high, many GaAs FET switches will operate with a higher P1dB power level, higher by perhaps 5 or 6 dB.

For driver switching speeds less than 10 ns at the expense of higher current consumption, consider using an ECL driver such as the Motorola MC10H350 ECL to TTL translator, as shown in Figure 4. This circuit can drive the switch directly without the need for level shifting capacitors and resistors.

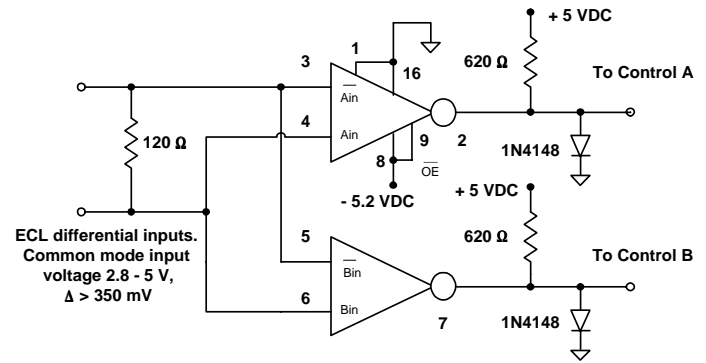

Tie inverting inputs of unused NOT gates to VCC, non-inverting inputs to ground to prevent output glitches. OE is inverse of output enable.

Figure 4: MC10H350 for Driving Dual Control Switches

Conclusion

This application note has explained how to control M/A-COM's GaAs FET switches and digital attenuators using drivers provided by M/A-COM, or using commercially available digital logic IC's. The appendix summarizes M/A-COM's most popular switches and classifies them by drive requirements. Careful choice of the switch or digital attenuator and the driver can provide optimum RF linearity, fast switching speed, low power consumption and small board footprint.

Additional Notes:

Application Note M537, *GaAs MMIC Based Control Components with Integral Drivers* defines performance parameters for switches and attenuators.

1. See Application Note M517, *MASW6010 GaAs SPDT Switch Performance and Driver Circuit Techniques* for additional information on designing with the SWD-109 and SWD-119 drivers.
2. For pin assignments and supply voltages for the SWD-109 and SWD-119 single/quad drivers, see the SWD-109/119 data sheet, available on the M/A-COM web site at www.macom.com.
3. See Application Note M521, *Positive Voltage Control of GaAs MMIC Control Devices* for more information on floating attenuators above ground potential.
4. See Application Note M539, *Drivers for GaAs MMIC Switches and Digital Attenuators* for more information on compression and intermodulation distortion and the operation of the SW-109 and SWD-119 drivers.
5. See manufacturers' data sheets and application notes for additional information on digital logic IC's.
6. Please contact your M/A-COM sales representative for information on the latest switches and attenuators.

Specifications subject to change without notice.

- North America: Tel. (800) 366-2266, Fax (800) 618-8883
- Asia/Pacific: Tel. +81-44-844-8296, Fax +81-44-844-8298
- Europe: Tel. +44 (1344) 869 595, Fax +44 (1344) 300 020

Visit www.macom.com for additional data sheets and product information.

Appendix

Popular M/A-COM GaAs FET switches

In the following tables, switching speed is the time from the 50 percent point of the control voltage rise or fall to the occurrence of 90 percent (on) or 10 percent (off) of the switched RF level.

Dual Control Negative Bias

Part No.	Type	Package	Switching Speed
SW-212	SPST	FP-13	6 ns
SW-214	SPST terminated	FP-13	6 ns
SW-226	SPDT terminated	CR-2	6 ns
SW-227	SPDT	CR-2	6 ns
SW-239	SPDT	SOIC-8	4 ns
SW-259	SPST terminated	SOIC-8	8 ns
SW-276	SPDT	CR-2	35 ns
SW-279	SPDT	SOIC-8	35 ns
SW-289	SP4T	SOIC-14	6 ns
SW-337, 338	SPDT terminated	SOIC-8	10 ns
SW-391 ¹	SPDT	SOT-26	42 ns
SW-392 ¹	SPDT	SOT-26	20 ns
SW-395 ¹	SPDT	SOT-26	8 ns
SW-419	SP4T	SOIC-24	16 ns
SW-425 ¹	SPDT	SOT-26	~ 20 ns
SW-437	SPDT	SOT-363	~ 8 ns
SW-439*	SPDT	MSOP-10	~ 34 ns

1. Contains no shunt FET's, hence can operate with positive control voltages without ground pull-up components if provided with DC blocking capacitors on all RF lines.

Dual Positive Control, Requires Positive Supply (Includes pull-up components on-chip)

Part Number	Type	Package	Switching Speed
SW-277	SPDT	SOIC-8	35 ns
SW-349	SPST terminated	SOIC-8	2 μ s
SW-394	SPDT	SOIC-8	36 μ s
SW-399	SPST	SOT-26	110 μ s

Single Control, Integral Driver, Requires Positive And Negative Supplies

Part Number	Type	Package	Switching Speed
SW05-0311	SPST, TTL/CMOS in	CR-9	150 ns
SW10-0312	SPDT, TTL/CMOS in	CR-9	150 ns
SW10-0313	SPDT, TTL/CMOS in	CR-9	150 ns
SW65-0014	SPST, TTL/CMOS in	SOIC-24	50 ns
SW65-0114	SPST, TTL/CMOS in	SOIC-24	50 ns
SW65-0214	SP3T, TTL/CMOS in	SOIC-24	50 ns
SW65-0313	SP2T, TTL/CMOS in	SOIC-16	50ns
SW65-0314	SP4T, TTL/CMOS in	SOIC-24	50 ns
SW65-0440	SP4T, absorptive, TTL/CMOS in	QSOP-24	50 ns
SW-110	SPDT, TTL/CMOS in	CR-9	35 ns
SW-311	SPST, TTL/CMOS in	CR-9	12 ns
SW-312	SPDT, TTL/CMOS in	CR-9	7 ns
SW-313	SPD, TTL/CMOS in	CR-9	18 ns
SW-335	SPDT, TTL /CMOS in	SOIC-8	200 ns
SW-224	SPDT, TTL in	TO-5-4	150 ns
SW- 225	SPDT, TTL in	FP-13	150 ns

Single Control, Integral Driver, Positive Supply

Part Number	Type	Package	Switching Speed
SW-205	SPDT, TTL in	DI-1	20 ns
SW-206	SPDT, CMOS in	DI-1	40 ns
SW-215	SPST, TTL in	DI-1	20 ns
SW-216	SPDT, CMOS in	DI-1	40 ns
SW-217	SPDT, TTL in	DI-1	20 ns
SW-233	SPDT, TTL in	FP-16	20 ns
SW-236	SPDT, CMOS in	FP-16	40 ns

Specifications subject to change without notice.

■ **North America:** Tel. (800) 366-2266, Fax (800) 618-8883
 ■ **Asia/Pacific:** Tel.+81-44-844-8296, Fax +81-44-844-8298
 ■ **Europe:** Tel. +44 (1344) 869 595, Fax+44 (1344) 300 020

Visit www.macom.com for additional data sheets and product information.